

Model 2100 Hall Effect Gaussmeter Probes

Probes are supplied with flash memory and a temperature sensor that allow the Model 2100 Gaussmeter to correct for Hall Element inaccuracies and inaccuracies due to temperature change. Probes are supplied with a NIST traceable Certificate of Calibration and test data.

Hall Effect Probes manufactured by Magnetic Instrumentation, Inc. are available in a wide range of styles and sizes. Magnetic Instrumentation, Inc. can manufacture custom probes to satisfy magnetic measuring requirements not covered by our standard probes. Contact our magnetics applications engineers for assistance.

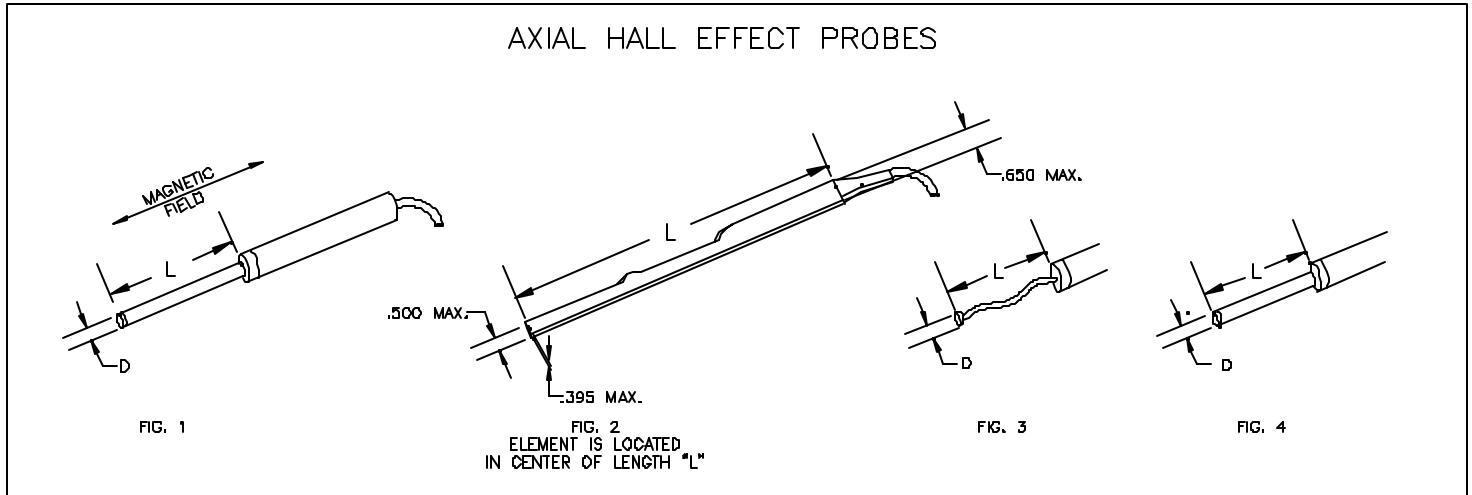

PROBE TYPE	MODEL #	DIMENSIONS (inches)		STEM & ELEMENT R-Rigid Stem S-Semi-Rigid Stem F-Flexible Stem E-Exposed Element Re-Recessed Element	CORRECTED ACCURACY ± (% OF READING) (PLUS 2 GAUSS)	FIGURE	THERMISTERS LOCATION H-HANDLE S-STEM	USABLE RANGE
		L ±.05	D Max.					
MINI (D ≤ .100)	2100-300-2	2	.100	R,E	.3% To 10KG	1	H	CODE A
	2100-300-5	5	.100	R,E	.3% To 10KG	1	H	CODE A
	2100-300-8	8	.100	R,E	.3% To 10KG	1	H	CODE A
	2100-301-2	2	.100	F,E	.3% To 10KG	3	H	CODE A
	2100-301-5	5	.100	F,E	.3% To 10KG	3	H	CODE A
	2100-301-8	8	.100	F,E	.3% To 10KG	3	H	CODE A
GENERAL PURPOSE	2100-315-2	2	.200	F,E	.3% To 10KG	3	H	CODE A
	2100-315-5	5	.200	F,E	.3% To 10KG	3	H	CODE A
	2100-315-8	8	.200	F,E	.3% To 10KG	3	H	CODE A
	2100-316-2	2	.255	R,Re	.3% To 10KG	4	S	CODE A
	2100-316-5	5	.255	R,Re	.3% To 10KG	4	S	CODE A
	2100-316-8	8	.255	R,Re	.3% To 10KG	4	S	CODE A
HIGH FIELD	2100-330-2	2	.260	R,E	.3% To 10KG 1% 10KG-100KG	1	S	CODE B
	2100-330-5	5	.260	R,E	.3% To 10KG 1% 10KG-100KG	1	S	CODE B
	2100-330-8	8	.260	R,E	.3% To 10KG 1% 10KG-100KG	1	S	CODE B
	2100-331-2	2	.260	F,E	.3% To 10KG 1% 10KG-100KG	3	H	CODE B
	2100-331-5	5	.260	F,E	.3% To 10KG 1% 10KG-100KG	3	H	CODE B
	2100-331-8	8	.260	F,E	.3% To 10KG 1% 10KG-100KG	3	H	CODE B
LOW FIELD	2100-450-9	9	See Diagram	R,Re	¹	2	S	CODE C

¹ Linearity 4% of reading to 2 Gauss

TRANSVERSE HALL EFFECT PROBES

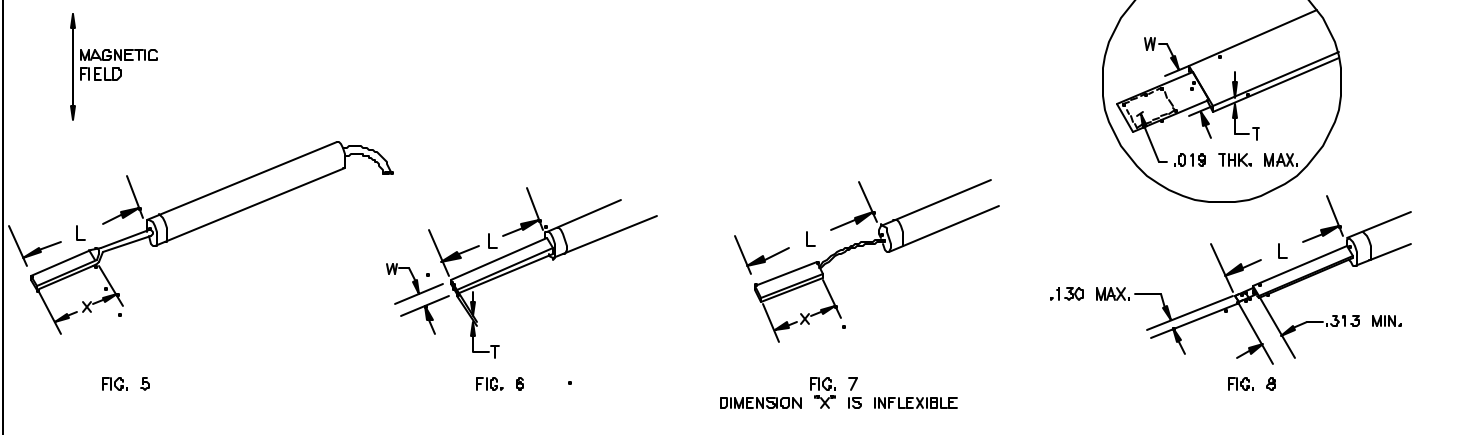

PROBE TYPE	MODEL #	DIMENSIONS (inches) L T W X ±.05 Max. Max. ±.05	STEM & ELEMENT R-Rigid Stem S-Semi-Rigid Stem F-Flexible Stem E-Exposed Element Re-Recessed Element	CORRECTED ACCURACY +/-(% OF READING) (PLUS 2 GAUSS)	FIGURE	THERMISTERS	USABLE RANGE
						LOCATION	
						H-HANDLE S-STEM	
MINI (T<.045") (W<.100")	2100-200-2	2.0 x .022 ² x .080 x 1.0	E,E	.3% To 10KG	7	H	CODE A
	2100-200-5	5.0 x .022 ² x .080 x 1.0	E,E	.3% To 10KG	7	H	CODE A
	2100-200-8	8.0 x .022 ² x .080 x 1.0	E,E	.3% To 10KG	7	H	CODE A
	2100-201-	1.6 x .041 x .100 x ---	S,Re	.3% To 10KG	6	H	CODE A
GENERAL PURPOSE	2100-215-2	2.0 x .023 ³ x .130 x 1.0	E,E	.3% To 10KG	7	H	CODE A
	2100-215-5	5.0 x .023 ³ x .130 x 1.0	E,E	.3% To 10KG	7	H	CODE A
	2100-215-8	8.0 x .023 ³ x .130 x 1.0	E,E	.3% To 10KG	7	H	CODE A
	2100-216-3	3.0 x .042 x .160 x ---	E,E	.3% To 10KG	8	H	CODE A
	2100-217-5	5.0 x .058 x .180 x 2.0	R,Re	.3% To 10KG	5	S	CODE A
	2100-217-8	8.0 x .058 x .180 x 2.0	R,Re	.3% To 10KG	5	S	CODE A
HIGH FIELD	2100-230-2	2.0 x .043 x .240 x 1.6	F,E	.3% To 10KG 1% 10KG-100KG	7	H	CODE B
	2100-230-5	2.0 x .043 x .240 x 1.6	F,E	.3% To 10KG 1% 10KG-100KG	7	H	CODE B
	2100-230-8	2.0 x .043 x .240 x 1.6	F,E	.3% To 10KG 1% 10KG-100KG	7	H	CODE B
	2100-231-2	2.0 x .082 x .310 x 1.6	R,Re	.3% To 10KG 1% 10KG-100KG	5	S	CODE B
	2100-231-5	5.0 x .082 x .310 x 1.6	R,Re	.3% To 10KG 1% 10KG-100KG	5	S	CODE B
	2100-231-8	8.0 x .082 x .310 x 1.6	R,Re	.3% To 10KG 1% 10KG-100KG	5	S	CODE B

² From tip of element back 5/16" thickness is .015" Max.

³ From tip of element back 3/16" thickness is .018" Max.

Usable Ranges:

Code A- 50G, 100G, 200G, 500G, 1KG, 2KG, 5KG, 10KG, 20KG

Code B- 500G, 1KG, 2KG, 5KG, 10KG, 20KG, 50KG, 100KG

Code C- 50mG, 100mG, 200mG, 500mG, 1G, 2G

Notes:

- All Probe handles have a diameter of approximately 7/16" and a length of approximately 2 5/8".
- Standard cable length is 6'. Longer cable lengths are available at additional cost.
- Hall Probes are fragile and must be handled with care.
- Axial probes are used to measure magnetic fields parallel to the probe handle.
- Transverse probes are used to measure magnetic fields perpendicular to their flat surfaces.
- Standard Certifications are to ±10KG range.